

Style 4 (p17)

Orion Style 4 tanks are manufactured in 15 gallon to 2400 gallon sizes. The style 4 tank is complete with a welded circular top. The 15 and 30 gallon tanks have a 6" clean out installed in the top of the tank for access. Above 55 gallons a 16" gamma plus access port is installed.



Style 5 (p17)

Orion Style 5 tanks are manufactured in 5 gallon to 2400 gallon sizes. The style 5 tank is complete with a bolted circular top. This top lifts off for access to the tank.

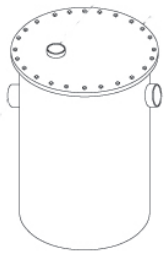

Style 7 (p17)

Orion Style 7 tanks are manufactured in all tank sizes. These tanks are fiberglass reinforced for additional strength. Typically, Style 7 tanks have the same access as a style 4. A bolted top is also available.

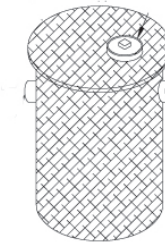

Tank Extensions (p22)

Tank extensions can be fabricated for any size; Style 4, 5 & 7 tank.

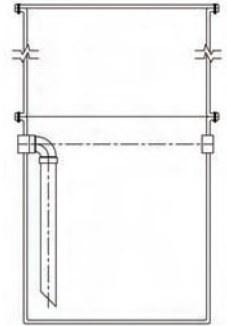

Double Wall Tanks (p22)

Orion can fabricate a variety of double wall tanks. These are custom designed in conjunction with the engineer.

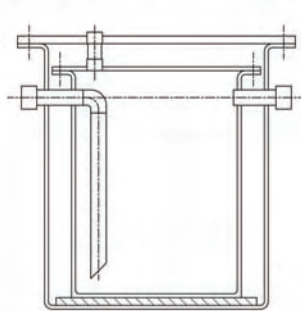

Rectangular Tank (p24)

For constricted areas Orion provides a variety of rectangular tanks.

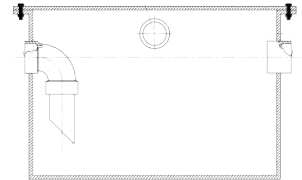

Style 8 (p12-13)

Orion Style 8 tanks are designed for point of use applications. These tanks have a 1½ gallon capacity. Without limestone these tanks serve as a dilution tank or sink trap. A 3" cleanout is installed on the top of the tank to provide access. Other configurations are available.

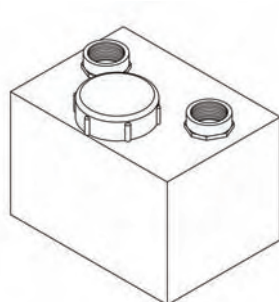

Style 9 (p13)

Orion Style 9 tanks are designed for use in applications that require a five gallon holding tank at point of use. The tank can serve as a neutralization tank when used with limestone chips. Without limestone it will serve as a dilution tank. The 6" cleanout installed in the center top of the tank provides access.

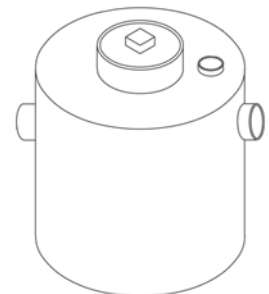

Tank Anchor Flange - (TAF)

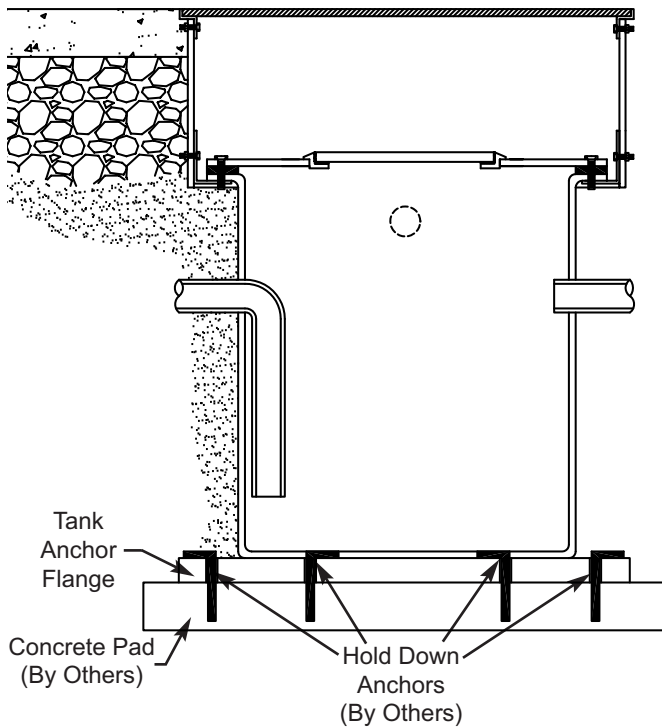

Tank Anchor Flanges are welded to the tank bottom and supplied with holes for hold down anchors (By Others) to attach to a concrete pad. Tank Anchor Flanges are recommended for securing the tank to the ground in partially full or high water table tank applications.

Reinforcing Anchor Flange - (RAF)

Reinforcing Anchor Flanges are vertical ribs welded to the outside of the tank included holes at the tanks bottom for hold down anchors (By Others) to attach the tank to a concrete pad. Reinforcing Anchor Flanges are typically used to structurally reinforce the tank for partially full tank applications..

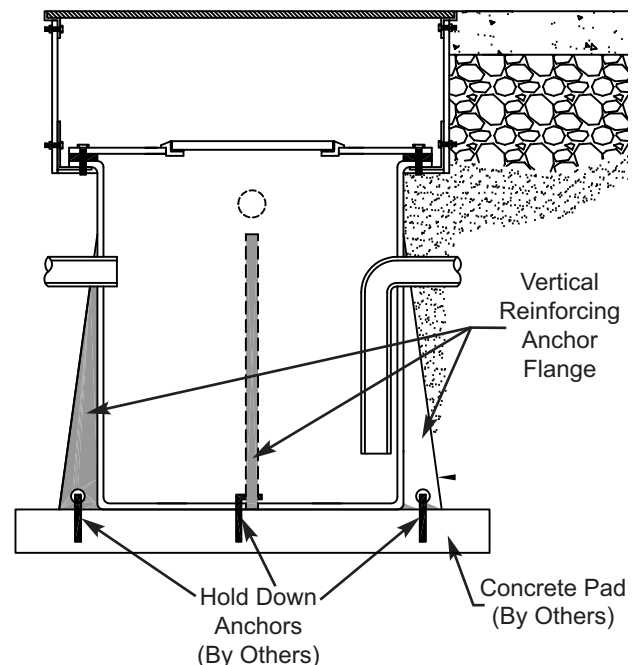

NEUTRALIZATION TANKS

STYLE 5 TANK COVER OPTIONS

Bolted Cover Options

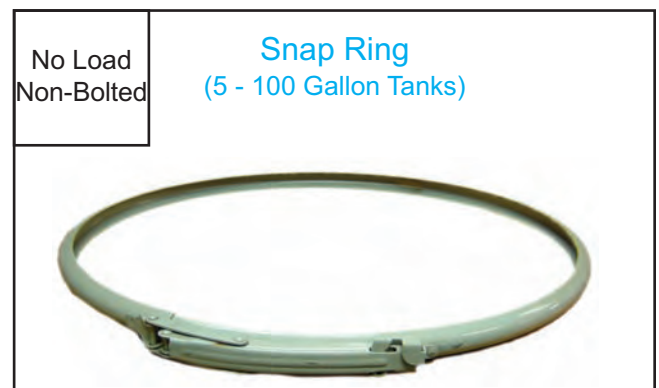
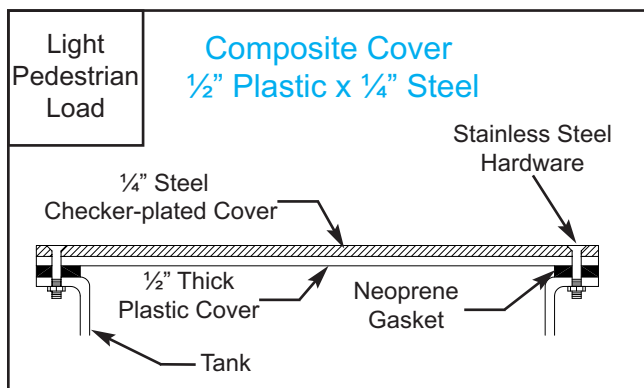
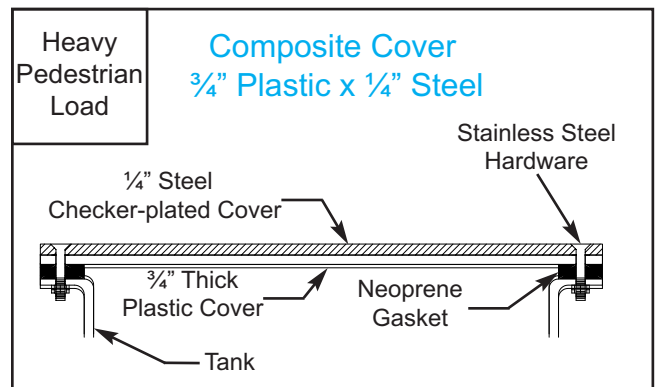
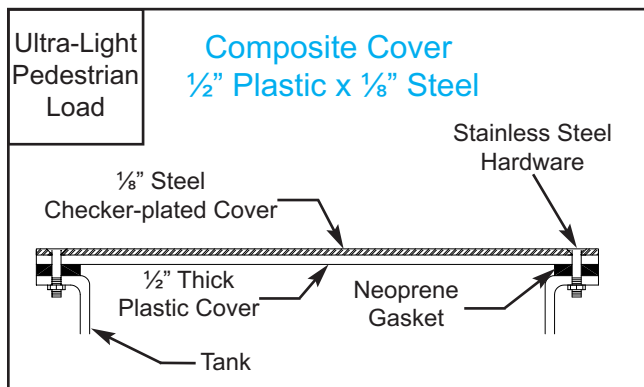
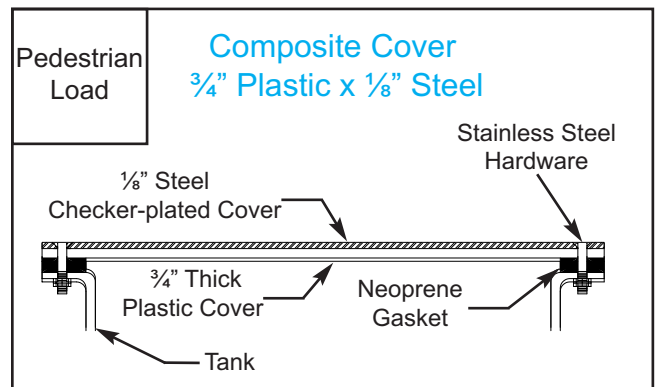
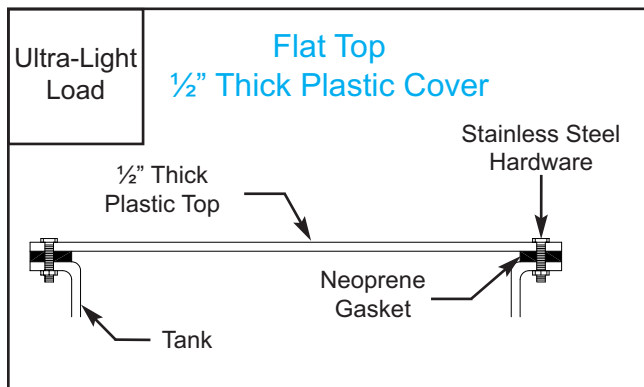
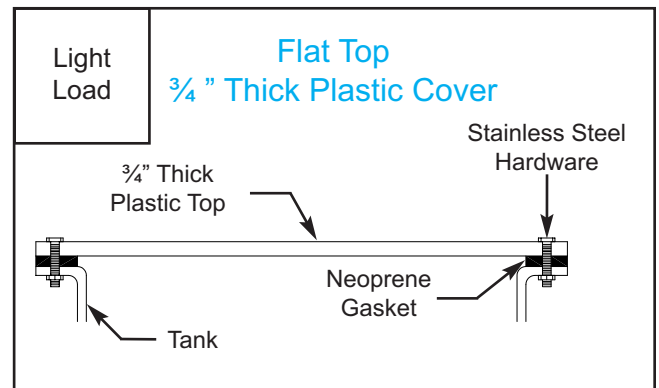
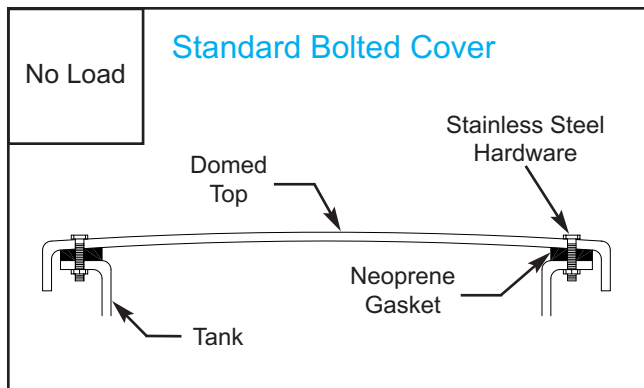

Adjustable Height

Certain applications require job site adjustability for tank extensions. Orion's offers a range of adjustable height from 5-Gallon to 600-Gallons. They are assembled to our standard tanks and can be supplied with the same options as standard tanks.

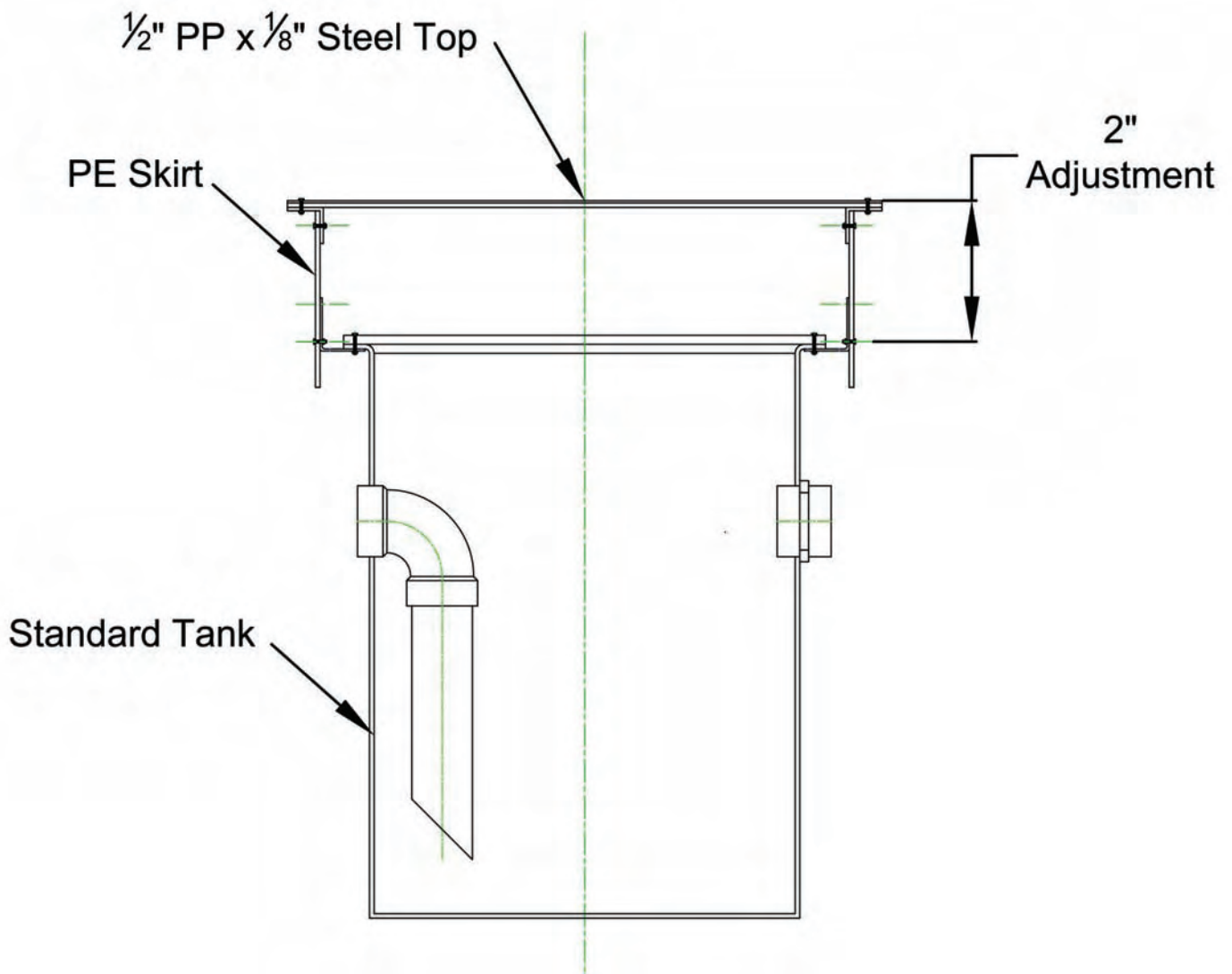

NEUTRALIZATION TANKS

INSPECTION PORTS & CONNECTION OPTIONS

Inspection Ports

3", 4" or 6"
Clean-Out

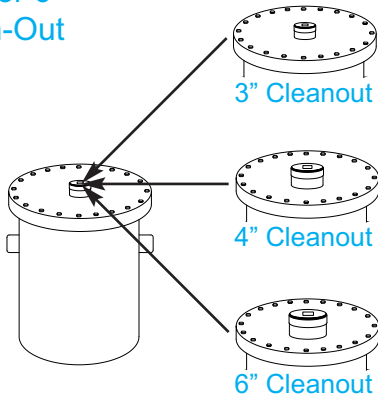

Gamma Top
12" Easy Threaded Access

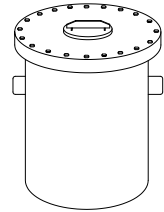

Gamma Plus
16" Easy Threaded Access

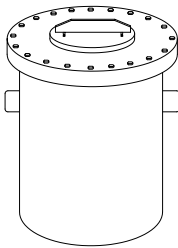

20" or 24"
Bolted Manway

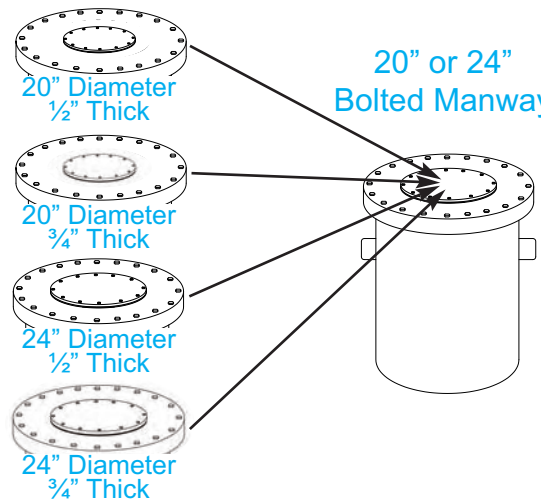

Connections

<p>Plain End</p>	<p>Connects to: Mechanical Joints Socket Ends</p> <p>Sizes: 1 1/2", 2", 3", 4", 6"</p>
-------------------------	--

<p>Connects to: Standard Male Pipe Thread</p> <p>Sizes: 1 1/2", 2", 3", 4", 6"</p>	<p>Female Thread</p>
--	-----------------------------

<p>Male Thread</p>	<p>Connects to: Standard Female Pipe Thread</p> <p>Sizes: 1 1/2", 2", 3", 4", 6"</p>
---------------------------	--

<p>Connects to: ANSI 150 lb Bolt Pattern</p> <p>Sizes: 1 1/2", 2", 3", 4", 6"</p>	<p>Flanged</p>
---	-----------------------

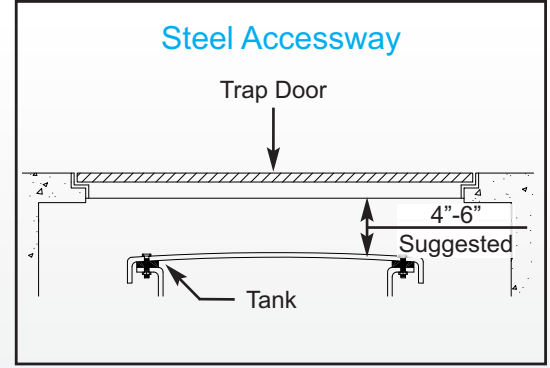

Suggested Trap Door Sizes For Orion Standard Tanks

Tank Size	Trap Door Size
5, 15, 30 galls	24"x24"
55, 100 galls	36"x36"
150, 180, 200 galls	48"x48"
275, 360, 500, 1200	60"x60"



TYPE OR: 150 PSF Steel With Loose Cover

Model	Dimensions
OR-24	24"x24"
OR-36	36"x36"
OR-48	48"x48"



TYPE K / TYPE Q: 150 PSF Hinged Cover

Model	Model	Dimensions
AL	Steel	
K1	Q1	24"x24"
K4	Q4	36"x36"
KD2	QD2	48"x48"
KD4	N/A	60"x60"

"D" represents a double door version



TYPE J: 300 PSF Hinged Cover

Model	Model	Dimensions
AL	Steel	
J1AL	J1	24"x24"
J4AL	J4	36"x36"
JD2AL	JD2	48"x48"
JD4AL	JD4	60"x60"

"D" represents a double door version



TYPE JH20: H-20 Wheel Loading

Model	Dimensions
Steel	
J1H20	24"x24"
J4H20	36"x36"
JD2H20	48"x48"
JD4H20	60"x60"

"D" represents a double door version